

## Workshop unit 313 micro liner

### Technical data sheet

- Compact and solid marking unit for flexible marking of bulky components
- Diversity of marking processes: stylus or dot marking
- DataMatrix coding (ECC 200)
- Marking area 120 x 20 mm
- Robust ball bearing spindles and carriage with circular ball track in both axes
- Drive is provided by powerful stepping motors
- Control (marking controller): EK-Box with membrane keyboard and display, protection class IP 54



313 micro liner with hand grips

### Application area

This easily transportable handheld unit for DotMatrix fonts and DataMatrix coding is best suited for many areas in industrial applications. The 313 micro liner is a mobile marking device and is operated manually. Even with bigger font sizes markings of one or more lines are possible. Due to its good ergonomic features and its easy way of operating, the device is eminently suited for usage in workshops, in quality control and in stock management. The marking unit 313 micro liner is available with hand grips as well as table and column for a flexible handling.

The 313 micro liner is setting new standards with a weight of only 3.5 kg. Measuring rather small, it still offers a large marking area of 120 x 20 mm. With the help of quick changing optional workpiece support it is possible to adapt to almost any workpiece geometries.

With the compact-controller BC7 there are numerous options of data input via PC, Barcode-scanner, SPS or the integrated membrane keyboard. Here, simple compilation and selection of the marking tasks is taking place as well. Font heights and font widths are freely scalable.

### Options

- Protective cover of the marker bottom side (protective bellows)
- Pneumatic infeed slide (50 mm, 80 mm or 100 mm range)
- Height adjustment with quick changing adaptor

## Technical Data

Property	Measure, Unit, Explanation	CO*	A0*
• Dimensions marking unit (W x D x H) without attaching parts	230 x 280 x 214 mm (dependent on workpiece edition)		
• Marking area (X/Y)	120 x 20 mm		
• Weight (without steorage/ controller)	ca. 3.5 kg		
• Writing speed (depending on character size and shape, marking process and motorisation)	up to 6 characters/ second		
• Character height	from 1 mm (enhancing in 0,1 mm steps)		
• Operating pressure pneumatic marking head	2 - 6 bar		
• Documentation	German, English or French more languages	X	X
• Penetration depth marking tip (depending on marking head, marking process and material)	ca. 0.01 – 0.5 mm (see data sheet marking heads)		
• Input supply voltage	115 or 230 V		
• DotMatrix character shape	7:5 dots in height/width		
• Alternative character shape	9:7 or OCRA		X
• Standard character shape	A-Z, a-z, 0-9 ,-/ DataMatrix ECC 200		
• Special characters, logos	according to original		X

\*) CO = construction option, will be defined by placing of order – no additional charge; A0 = additional option, can be ordered additionally – additional charge



313 micro liner optional with table and column

Workpiece support for plain workpieces

Prism support for round workpieces optional

Technical details are subject to change.

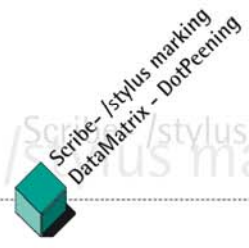

### 313 with table and column

Dimensions of the marking heads see spreadsheet 313 without protective bellows

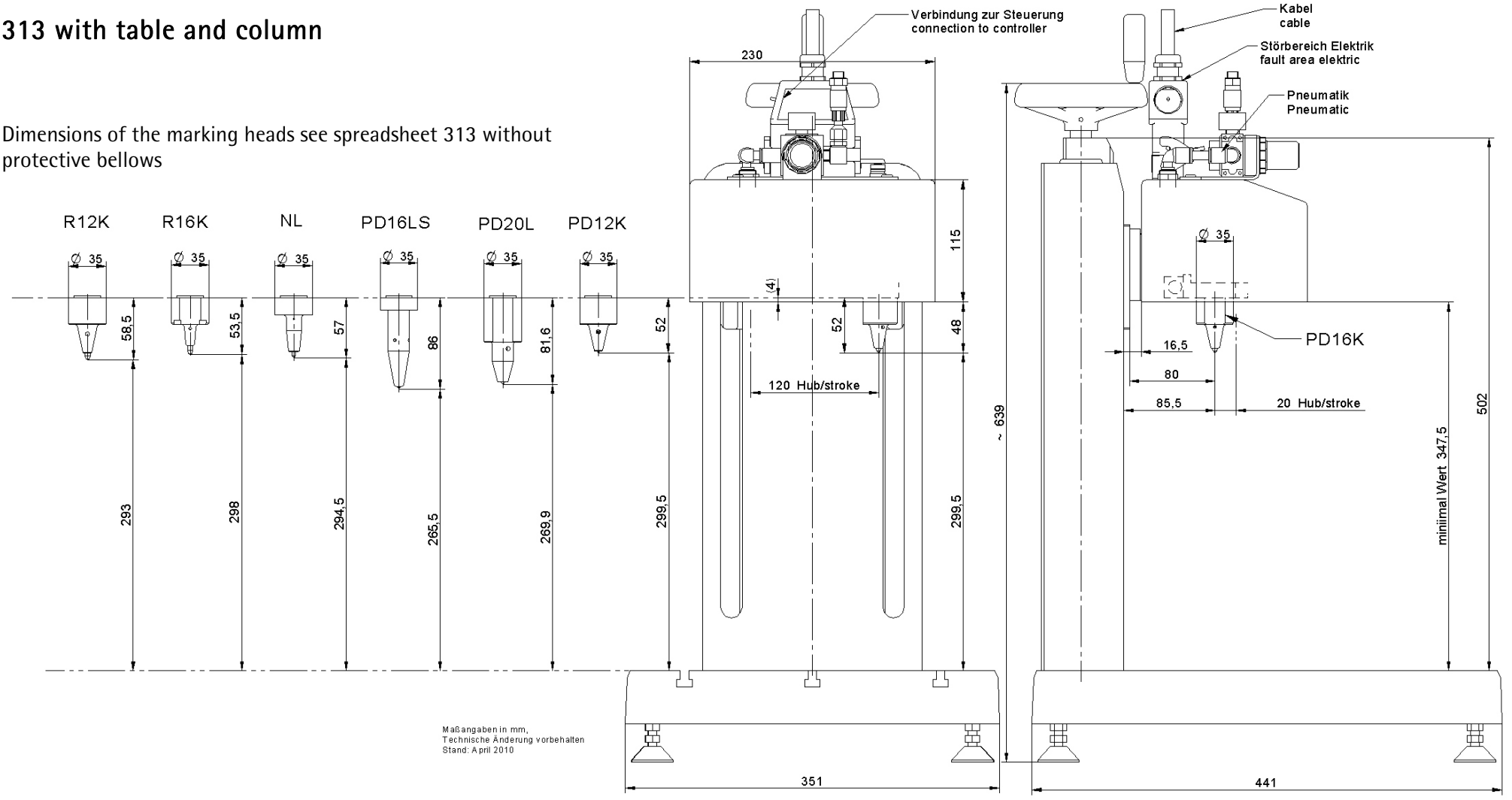

## 313 with table and column as well as with hand grips Quick changing system

Dimensions of the marking heads see spreadsheet 313 without protective bellows

