

## Compact-controller BC7 EK-Box

### Technical data sheet

- Universal 2-axis marking controller in compact housing
- Protection category IP54 – independently of control cabinet installation
- For marking machines and units of the series 312 and 313
- Scribe, stylus, DataMatrix and dot matrix marking heads can be used
- With integrated membrane keyboard and display with four lines on the front side
- MACRO program: maximum capacity of 40 different marking pictures (layouts) are storable as well as fixed texts, date, time, shift and counters are available



### Application area

The marking controller can be used in marking stations with manual or automated workpiece handling. It is integrable in direct environment to the marking unit without further complexity and can be used for the marking units 312 and 313 with 2-axis.

The marking controller is equipped with a standard MACRO program and can be integrated into a higher-level station control. All parameter settings can be modified using the membrane keyboard (also marker text and positions) or the BORRIES MACRO loader program. With this program a test and setup operation is also possible including teach-in features on marking positions.

It is possible to load the marking data from the outside into the controller (Barcode Scanner for instance) as well as to start the marking workflow by a higher-level station control.

### Option

- Different interfaces for data transfer possible
- External display with membrane keyboard and display (operation and status display out of a safety fence possible)

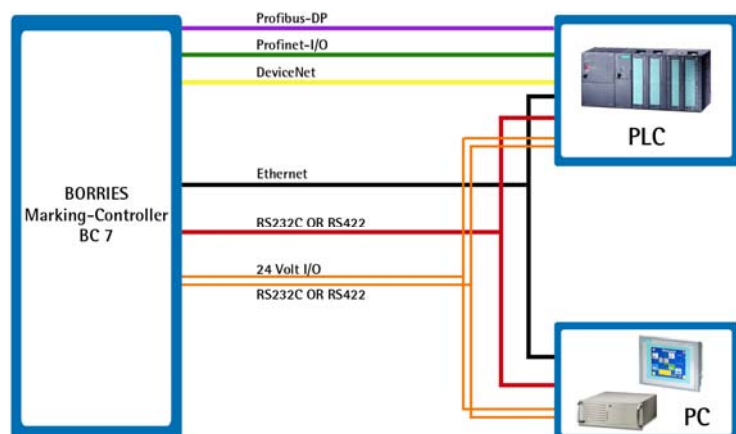

## Technical Data

Property	Measure, Unit, Explanation	CO*	AO*
• Measurements	see drawing		
• Power supply (50 ... 60 Hz) standard	230/50 V ± 10 %		
• Alternative (internally switchable)	115/60 V ± 10 %	X	
• Power consumption	210 W		
• Environmental temperature	max. 40 °C/ 104 F		
• Heat removal over housing			
• Protection category	IP 54 (power supply unit IP 53)		
• EMV guidelines 89/336 EWG	yes, is fulfilled		
• Cable length marker to marking controller	3 m	X	
	5 m or 10 m		X
• 1. serial interface	RS232/ RS422 switchable, USB	X	
• 2. serial interface	RS232/ RS422 switchable (data transfer, control)	X	
• Ethernet interface	Ethernet (alternative for 1. and 2. serial interface)	X	
• Bus-Interface (data and I/O)	Profibus DP (internal)		X
	Profinet I/O (internal)		X
• Real-Time-Clock backed	date, time, shift identification	X	
• Free digital I/O 24 V	12E+8A, opto isolated, short-circuit proof		X
• Emergency switch off via two external normally closed contacts			
• LCD Display and alpha membrane keyboard	in the housing cover integrated (via PS2 external keyboard possible)		
• DataMatrix conversion in the controller	ECC 200 up to 52 x 52 or 16 x 48 dots		X
• Logo(s)	on request		X
• Standard MACRO program purely serial	see separate data sheet	X	
• Keyboard MACRO program	see separate data sheet	X	
• VisuWin SE	see separate data sheet	X	
• Customer specific MACRO program	on request according to specification		X

\*) CO = construction option, will be defined by placing of order – no additional charge; AO = additional option, can be ordered additionally – additional charge

Technical details are subject to change.